

US009024302B2

(12) **United States Patent**
Sumida et al.

(10) **Patent No.:** **US 9,024,302 B2**
(45) **Date of Patent:** **May 5, 2015**

(54) **DISPLAY DEVICE**

(71) Applicant: **Canon Kabushiki Kaisha**, Tokyo (JP)

(72) Inventors: **Noa Sumida**, Chiba (JP); **Kiyofumi Sakaguchi**, Mobarra (JP)

(73) Assignee: **Canon Kabushiki Kaisha**, Tokyo (JP)

(*) Notice: Subject to any disclaimer, the term of this patent is extended or adjusted under 35 U.S.C. 154(b) by 149 days.

(21) Appl. No.: **13/917,356**

(22) Filed: **Jun. 13, 2013**

(65) **Prior Publication Data**

US 2013/0277659 A1 Oct. 24, 2013

Related U.S. Application Data

(63) Continuation of application No. 12/893,929, filed on Sep. 29, 2010, now Pat. No. 8,497,498.

(30) **Foreign Application Priority Data**

Oct. 2, 2009 (JP) 2009-230648

(51) **Int. Cl.**

H01L 27/32 (2006.01)

H01L 51/52 (2006.01)

(52) **U.S. Cl.**

CPC **H01L 51/5253** (2013.01); **H01L 51/5246** (2013.01); **H01L 51/5256** (2013.01); **H01L 27/3244** (2013.01); **H01L 51/5237** (2013.01); **H01L 51/5275** (2013.01); **H01L 27/32** (2013.01)

(58) **Field of Classification Search**

CPC H01L 27/32

USPC 257/40, 100

See application file for complete search history.

(56) **References Cited**

U.S. PATENT DOCUMENTS

5,936,347	A *	8/1999	Isaka et al.	313/509
6,660,409	B1 *	12/2003	Furukawa et al.	428/690
7,745,840	B2 *	6/2010	Wang et al.	257/95
7,852,563	B2 *	12/2010	Mizutani et al.	359/620
2005/0007669	A1 *	1/2005	Sakai	359/619
2011/0031514	A1 *	2/2011	Sakaguchi et al.	257/88
2012/0057100	A1 *	3/2012	Masuda et al.	349/62
2012/0223873	A1 *	9/2012	Ohta	345/76

* cited by examiner

Primary Examiner — Evan Pert

(74) *Attorney, Agent, or Firm* — Canon U.S.A. Inc., IP Division

(57) **ABSTRACT**

A display device includes an array of pixels including a plurality of organic EL elements each having a pair of electrodes and an organic compound layer including a light-emitting layer and disposed between the pair of electrodes and includes a protective layer disposed on the plurality of the organic EL elements. The protective layer has a first protective layer made of an inorganic material, a second protective layer made of a resin material and disposed on the first protective layer, and a third protective layer made of an inorganic material and disposed on the second protective layer. The second protective layer includes lenses for diverging at least part of light emitted from the light-emitting layer. The lenses have an elongated concave shape.

9 Claims, 8 Drawing Sheets

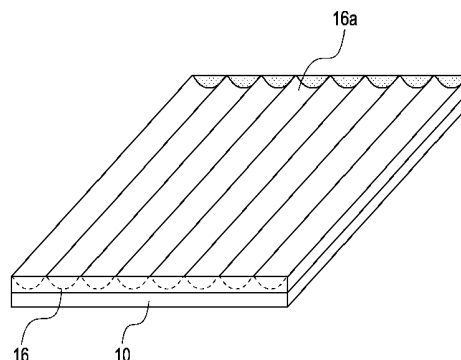
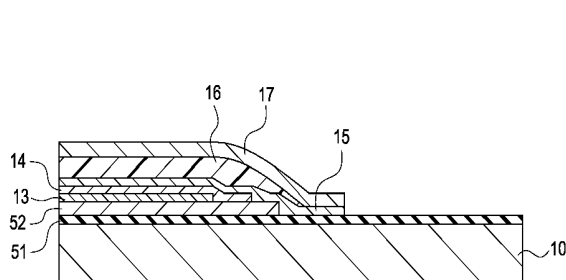
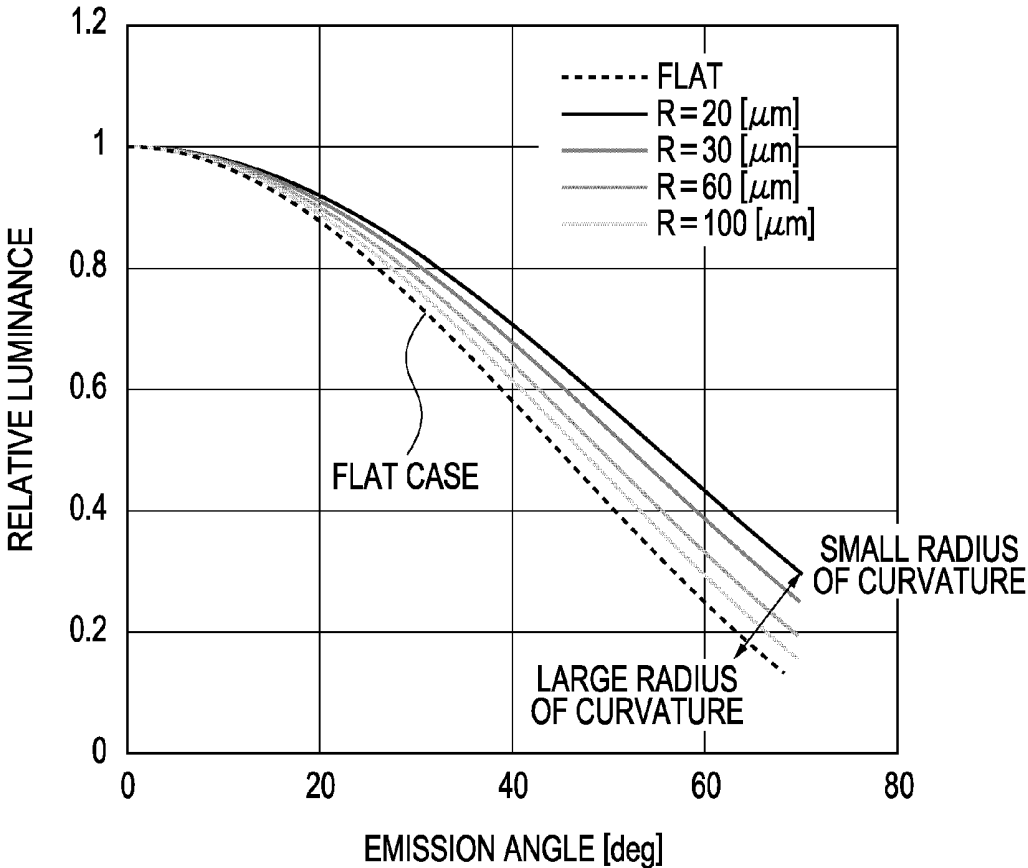

FIG. 3



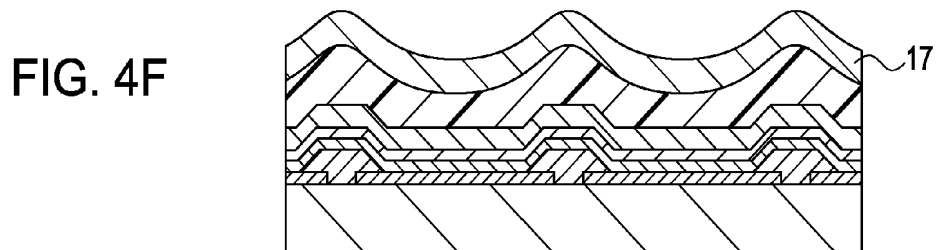
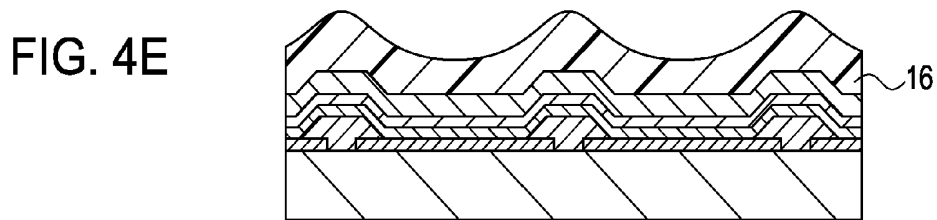
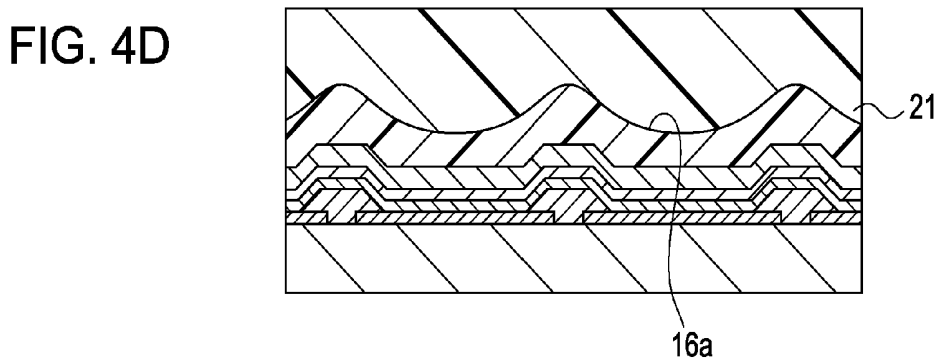
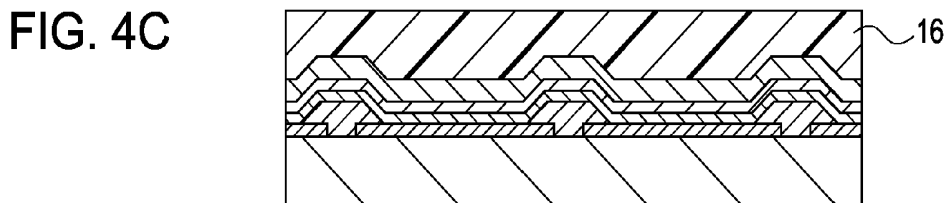
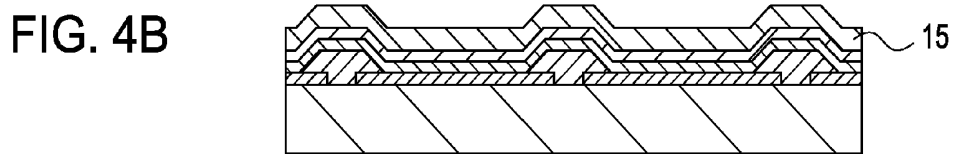
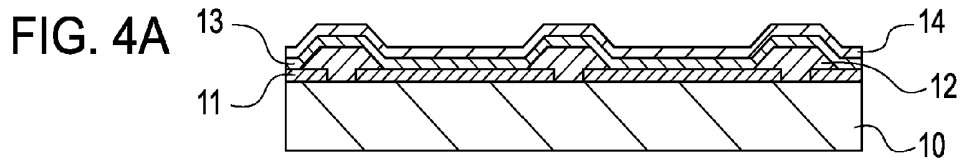

FIG. 5

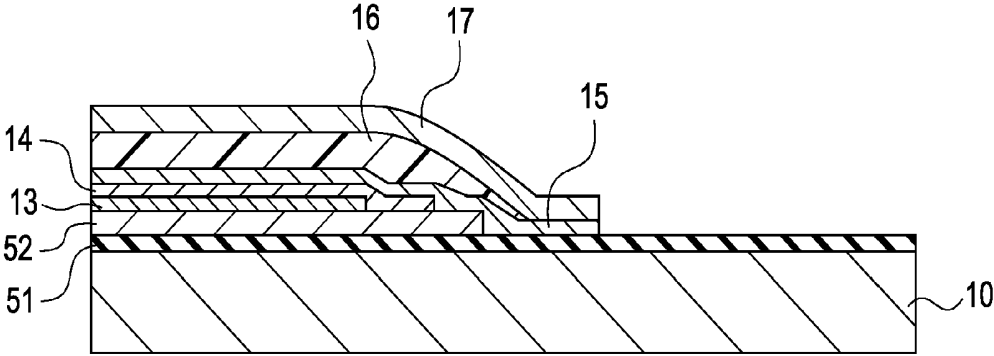

FIG. 6A

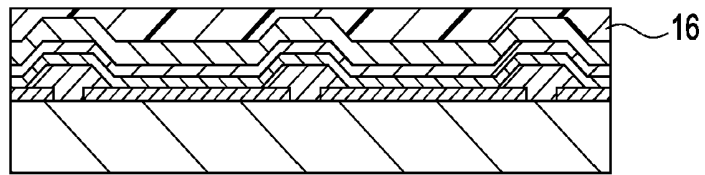

FIG. 6B

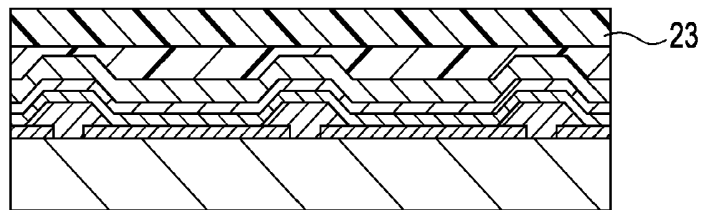

FIG. 6C

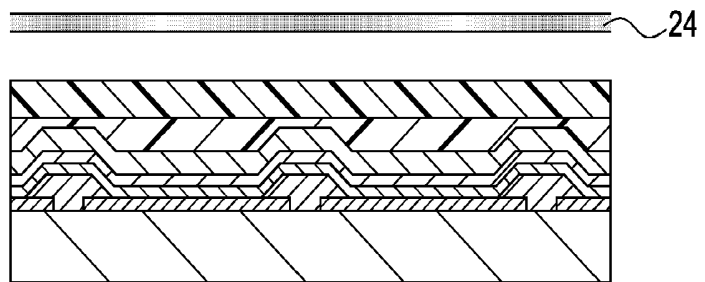

FIG. 6D

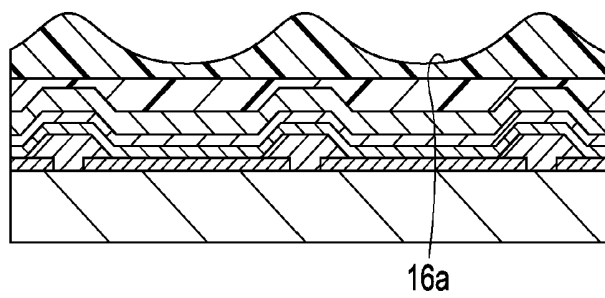

FIG. 6E

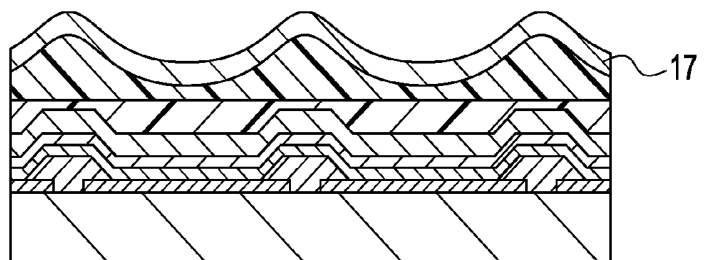

FIG. 7

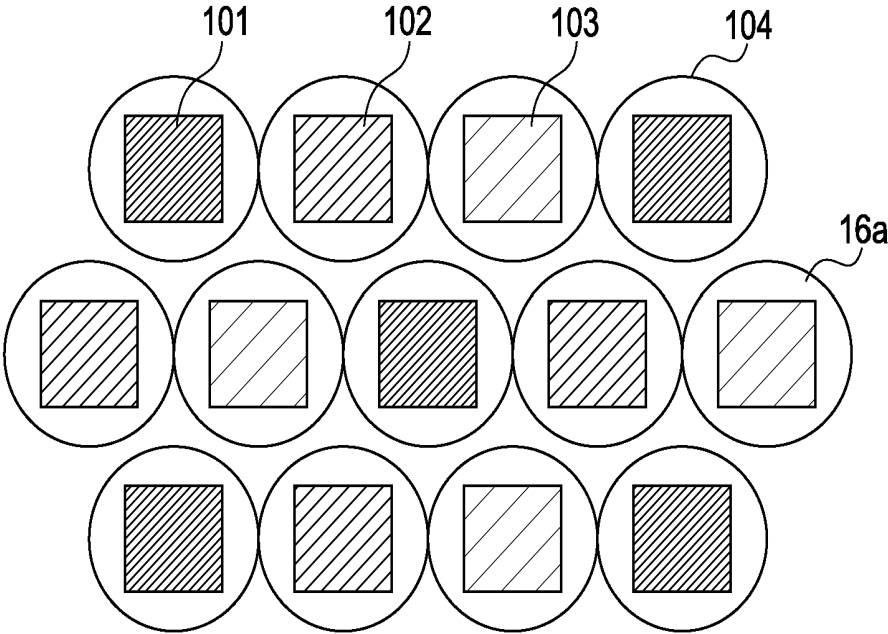

FIG. 8A

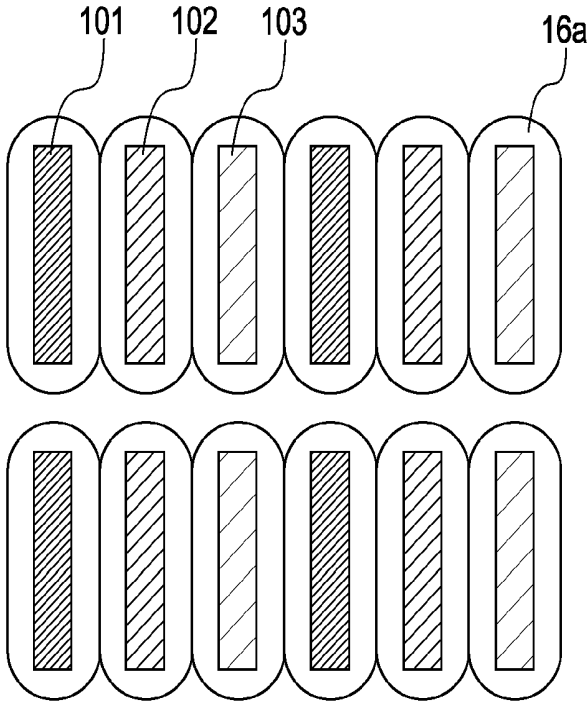

FIG. 8B

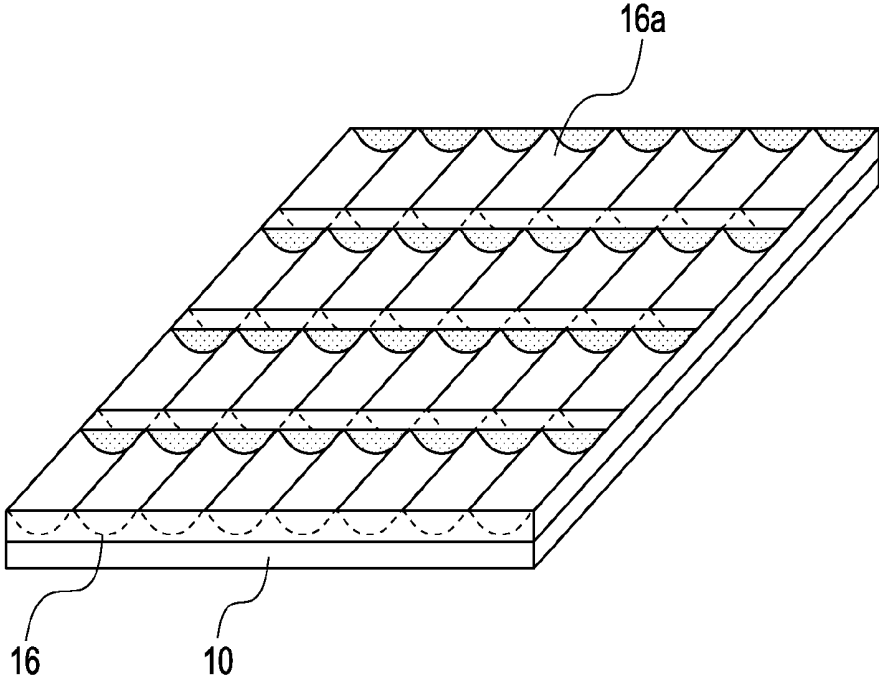

FIG. 9A

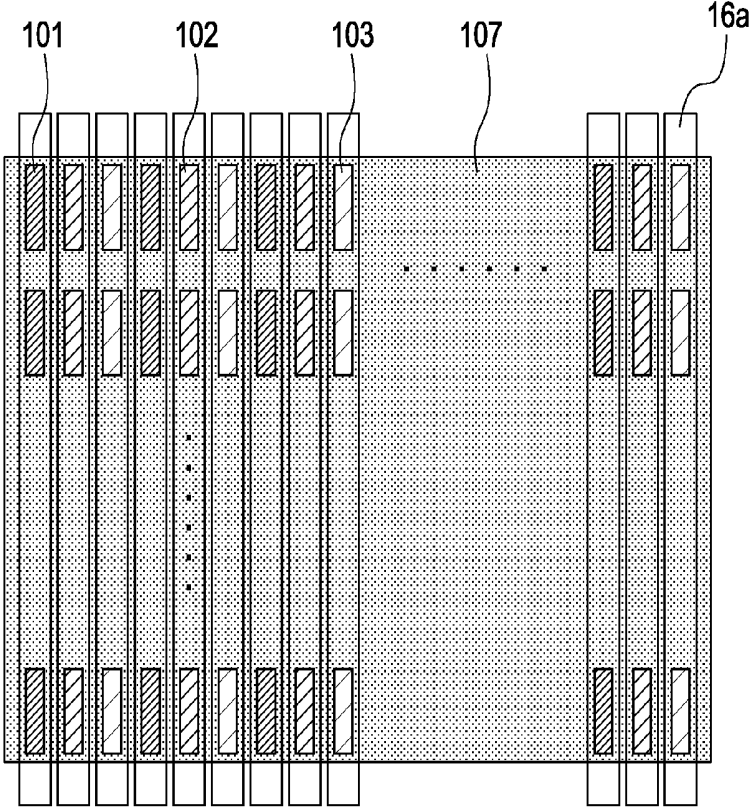
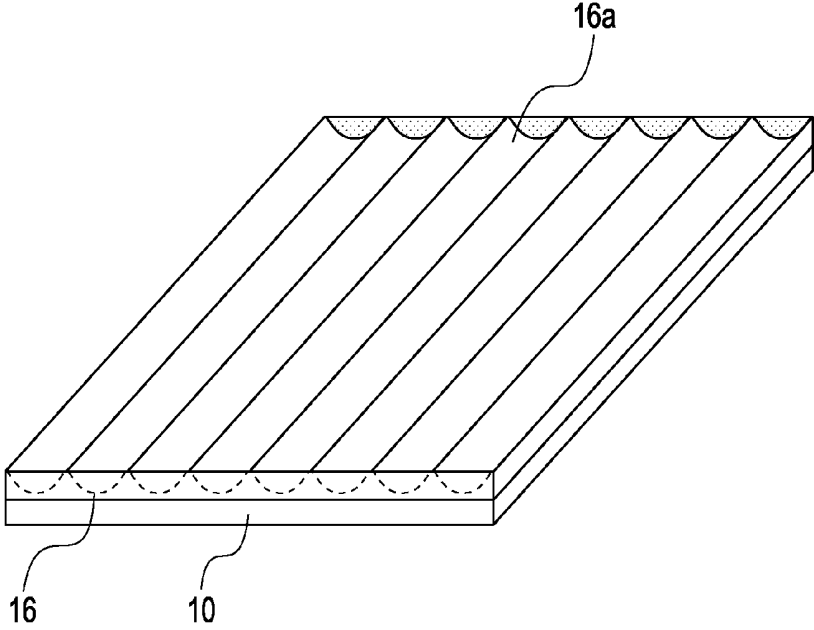

FIG. 9B



1

DISPLAY DEVICE

CROSS REFERENCE TO RELATED APPLICATIONS

This application is a Continuation of U.S. patent application Ser. No. 12/893,929 filed Sep. 29, 2010, which claims priority to JP 2009-230648 filed Oct. 2, 2009, each of which are hereby incorporated by reference herein in their entireties.

BACKGROUND OF THE INVENTION

1. Field of the Invention

The present invention relates to a display device having organic electroluminescent (EL) elements and specifically relates to a display device having organic EL elements that can improve view angle characteristics.

2. Description of the Related Art

Organic compound layers, such as electrodes of organic EL elements, light-emitting layers, and hole-transporting layers, are easily corroded or oxidized by reaction with moisture or oxygen in air. Such corrosion and oxidation significantly develop non-light-emitting portions, so-called dark spots, and cause characteristic degradation of the organic EL elements as time passes. Factors causing dark spots will now be described.

Usually, the surfaces of the organic EL elements are covered with a protective layer for preventing the organic compound layer from being brought into contact with moisture or oxygen in air. However, pinholes may be partially formed in the protective layer due to particles such as etching residues generated in the production process and dust. Then, oxygen and moisture penetrate through the pinholes into the insides of the elements to form dark spots. In order to prevent the penetration of oxygen and moisture, the protective layer may be thick so as to sufficiently cover the particles. However, since a protective layer made of an inorganic material, such as SiN, is formed by CVD or the like, it takes a long time to form the layer to be thick, resulting in a problem of increasing cost. At the same time, a design is proposed where a resin layer, which can be conveniently formed by application or the like, is formed for sufficiently covering the particles and a protective layer of a dense inorganic material is further formed on the resin layer.

Japanese Patent Laid-Open No. 2002-025765 discloses a sealing technique involving forming of a protective layer having a laminate structure composed of silicon nitrided oxide (SiON) layer/organic material layer/silicon nitrided oxide (SiON) layer on the upper electrode of the organic EL element.

Furthermore, in Japanese Patent Laid-Open No. 2005-19148, in order to give satisfactory irradiation distribution and provide natural visibility, a micro optical element having negative refractive power is formed on the upper surface of a covering layer (for example, SiO₂) covering the organic EL element.

Incidentally, combination of the protective layer having a laminate structure disclosed in Japanese Patent Laid-Open No. 2002-025765 and the micro optical element (concave microlens) having a negative refractive index shown in Japanese Patent Laid-Open No. 2005-19148 causes the following problems.

That is, when a microlens array made of a resin is disposed on a laminate structure serving as a protective layer, the microlens layer itself is exposed to the exterior atmosphere. Therefore, moisture in the atmosphere readily penetrates into

2

the microlenses to cause changes in the refractive index and the shape due to swelling, resulting in a decrease in lens function.

In order to solve this problem, an outermost protective layer made of an inorganic material such as SiN may be formed on the surfaces of the microlenses. In such a case, the layer structure has five layers including the protective layer composed of three layers and the resin layer constituting the microlenses, which leads to an increase of cost.

In addition, in such a structure, the number of layer interfaces constituting reflecting interfaces is increased, and thereby the quantity of emitted light that is trapped in the element is increased. As a result, the total quantity of light extracted to the outside is decreased, and also thereby luminance in an oblique direction is decreased, which leads to degradation in view angle characteristics.

SUMMARY OF THE INVENTION

A first aspect of the present invention relates to a display device including an array of pixels having a plurality of organic EL elements each having a pair of electrodes and an organic compound layer including a light-emitting layer and disposed between the pair of electrodes, and including a protective layer disposed on the plurality of the organic EL elements. The protective layer has a first protective layer made of an inorganic material, a second protective layer made of a resin material and disposed on the first protective layer, and a third protective layer made of an inorganic material and disposed on the second protective layer. The second protective layer includes lenses for diverging at least part of light emitted from the light-emitting layer, and the lenses have an elongated concave shape.

Another aspect of the present invention relates to a display device including an array of pixels having organic EL elements each having a pair of electrodes and an organic compound layer including a light-emitting layer and disposed between the pair of electrodes, and including a protective layer disposed on the plurality of the organic EL elements. The protective layer includes elongated concave-shaped lenses for diverging at least part of light emitted from the light-emitting layer.

Yet another aspect of the present invention relates to a display device including an array of pixels including organic EL elements each having a pair of electrodes and an organic compound layer including a light-emitting layer and disposed between the pair of electrodes, and including elongated concave-shaped lenses for diverging at least part of light emitted from the light-emitting layer.

Further features of the present invention will become apparent from the following description of exemplary embodiments with reference to the attached drawings.

BRIEF DESCRIPTION OF THE DRAWINGS

FIG. 1 is a partial cross-sectional view illustrating an embodiment of the present invention.

FIG. 2 is a partial cross-sectional view illustrating a known structure.

FIG. 3 is a graph showing a correlation between emission angle and relative luminance.

FIG. 4A is a diagram illustrating an embodiment of a process of manufacturing a display device according to aspects of the present invention.

FIG. 4B is a diagram illustrating an embodiment of a process of manufacturing a display device according to aspects of the present invention.

FIG. 4C is a diagram illustrating an embodiment of a process of manufacturing a display device according to aspects of the present invention.

FIG. 4D is a diagram illustrating an embodiment of a process of manufacturing a display device according to aspects of the present invention.

FIG. 4E is a diagram illustrating an embodiment of a process of manufacturing a display device according to aspects of the present invention.

FIG. 4F is a diagram illustrating an embodiment of a process of manufacturing a display device according to aspects of the present invention.

FIG. 5 is a cross-sectional view illustrating a state of a protective layer at the outside of the display region according to an embodiment of the present invention.

FIG. 6A is a diagram illustrating an embodiment of a process of manufacturing a display device in Example 2 of the present invention.

FIG. 6B is a diagram illustrating an embodiment of a process of manufacturing the display device in Example 2 of the present invention.

FIG. 6C is a diagram illustrating an embodiment of a process of manufacturing the display device in Example 2 of the present invention.

FIG. 6D is a diagram illustrating an embodiment of a process of manufacturing the display device in Example 2 of the present invention.

FIG. 6E is a diagram illustrating an embodiment of a process of manufacturing the display device in Example 2 of the present invention.

FIG. 7 is a diagram illustrating a pixel array and a concave lens shape of a display device according to aspects of the present invention.

FIG. 8A is a front view illustrating another pixel array and a concave lens shape of a display device according to aspects of the present invention.

FIG. 8B is a perspective view illustrating the pixel array and the concave lens shape of the display device according to aspects of the present invention.

FIG. 9A is a front view illustrating further another pixel array and a concave lens shape of a display device according to aspects of the present invention.

FIG. 9B is a perspective view illustrating the pixel array and the concave lens shape of the display device according to aspects of the present invention.

DESCRIPTION OF THE EMBODIMENTS

Organic EL Display Device

A display device according to embodiments of the present invention will be described with reference to the drawings below.

FIG. 1 is a partial cross-sectional view of a display device according to an Embodiment of the present invention. The display device is a top-emission-type where light is extracted to the upper direction in FIG. 1 from the upper side of organic EL elements formed on a board.

The display device according to aspects of the present invention includes a board 10 and a plurality of pixels formed in a matrix form to constitute a display region on the board 10. In this description, the term "pixel" means a region corresponding to one light-emitting element. According to aspects of the present invention, an organic EL element serving as a light-emitting element is formed in each of the plurality of pixels, and pixel separation layers 12 separating each of the pixels are disposed between the organic EL elements. In

addition, the organic EL elements each have a pair of electrodes, namely, an anode electrode 11 and a cathode electrode 14, and an organic compound layer 13 (hereinafter, referred to as organic EL layer) including a light-emitting layer and disposed between the pair of electrodes. Specifically, the anode electrode 11 patterned for each pixel is formed on the board 10, and the organic EL layer 13 is formed on the anode electrodes 11, and the cathode electrode 14 is further formed on the organic EL layer 13.

The anode electrodes 11 are made of, for example, an electrically conductive metal material having a high reflectance, such as Ag. In addition, the anode electrodes 11 may be a laminate constituted of a layer made of such a metal material and a layer made of an electrically conductive transparent material such as indium-tin-oxide (ITO) having an excellent hole-injection property.

On the other hand, the cathode electrode 14 is a common electrode for the plurality of the organic EL elements and has a semi-reflective or light-permeable constitution such that light emitted from the light-emitting layer can exit to the outside of the element. Specifically, in the case that the cathode electrode 14 is semi-reflective for enhancing the interference effect inside the element, the cathode electrode 14 is formed as a layer having a thickness of 2 to 50 nm and made of an electrically conductive metal material having an excellent electron-injection property, such as Ag and AgMg. Incidentally, the term "semi-reflective" means a property of partially reflecting and partially permeating light emitted at the inside of an element and refers to one having a visible light reflectance of 20 to 80%. In addition, the term "light permeability" refers to one having a visible light transmittance of 80% or more.

In addition, the organic EL layer 13 has a monolayer or multilayer structure including at least a light-emitting layer. Examples of the structure of the organic EL layer 13 include a four-layer structure comprising a hole-transporting layer, a light-emitting layer, an electron-transporting layer, and an electron-injection layer; and a three-layer structure comprising a hole-transporting layer, a light-emitting layer, and an electron-transporting layer. The materials for the organic EL layer 13 may be known materials.

The board 10 is provided with pixel circuits such that each of the organic EL elements can be independently driven. The pixel circuits comprise a plurality of transistors (not shown). The board 10 provided with the transistors is covered with an interlayer insulating layer (not shown) made of SiN and provided with contact holes for electrically connecting the transistors to the respective anode electrodes 11. Furthermore, a planarizing layer (not shown) made of an acrylic resin for absorbing the surface asperities due to the pixel circuits and thus planarizing the surface is disposed on the interlayer insulating layer.

Furthermore, a protective layer for protecting the organic EL layer 13 from oxygen and moisture in air is disposed on the cathode electrode 14.

The protective layer has a three-layer structure comprising a first protective layer 15, a second protective layer 16, and a third protective layer 17 in this order from the cathode electrode 14 side.

The first protective layer 15 is made of an inorganic material such as SiN or SiON and protects the organic EL layer 13 from moisture contained in the resin material constituting the second protective layer 16, which is laminated on the first protective layer 15. In addition, the first protective layer 15 can have a function of absorbing the stress generated when

the resin material is cured. The first protective layer **15** can have a thickness of 0.1 μm or more and 1.0 μm or less and can be formed by CVD.

The second protective layer **16** is made of a transparent resin material with a low moisture content, for example, 100 ppm or less. Regarding the transparency, the second protective layer **16** can have a visible light transmittance of 90% or more when the thickness is 10 μm . The resin material can be a thermosetting resin, a photo-setting resin, or a thermoplastic resin. Examples of these resins include epoxy resins, polyurethane setting-type resins, phenol resins, urea resins, melamine resins, alkyd resins, acrylic reactive resins, and formaldehyde resins. Furthermore, examples of these resins include silicon resins, epoxy-polyamide resins, mixtures of a polyester resin and an isocyanate prepolymer, mixtures of a polyester polyol and a polyisocyanate, mixtures of a polyurethane and a polyisocyanate, polymers or copolymers having structural units of vinyl chloride, vinyl acetate, vinyl alcohol, maleic acid, acrylic acid, an acrylic ester, vinylidene chloride, acrylonitrile, methacrylic acid, a methacrylic ester, styrene, butadiene, ethylene, vinyl butyral, vinyl acetal, vinyl ether, etc., and various types of rubber resins. As described below, the second protective layer **16** includes concave lenses. Therefore, the second protective layer **16** does not have a uniform thickness. The minimum thickness, that is, the thinnest portion, can have a thickness of 1 μm or more but not higher than 50 μm . The thickest portion can have a thickness of from 10 μm to 100 nm. The second protective layer **16** can be formed by coating or printing.

The third protective layer **17** is made of an inorganic material such as SiN and prevents penetration of oxygen and moisture from the outside to the insides of the organic EL elements. The third protective layer **17** can have a thickness of 0.5 μm or more and 5.0 μm or less and can be formed by CVD.

The second protective layer **16** includes a plurality of concave lenses **16a** in an array form on the light-extracting side (the upper direction of FIG. 1). The lenses **16a** are formed by processing the resin material constituting the second protective layer **16**. Specifically, the lenses **16a** can be formed by a method such as embossing. The lenses **16a** can be arranged in such a manner that one lens **16** corresponds to one pixel (that is, one organic EL element), but a plurality of lenses may correspond to one pixel, or one lens may correspond to a plurality of pixels. Furthermore, the third protective layer **17** is formed along the shapes of the lenses **16a**.

By forming such a structure, for example, when each pixel is provided with one lens **16a**, the light emitted from the organic EL layer **13** permeates through the transparent cathode electrode **14** and then permeates through the first protective layer **15**, the lens array formed in the second protective layer **16**, and the third protective layer **17** to be emitted to the outside of the organic EL elements.

If the lenses **16a** are not formed (FIG. 2), the light **18** obliquely emitted from the light-emitting layer of the organic EL layer **13** is further tilted (in the direction of **20**) when it is emitted from the third protective layer **17**. On the other hand, as shown in FIG. 1, in the structure that the lenses **16a** are formed, the emission angle of the light **19** emitted from the third protective layer **17** further verges (in the direction of **19**) toward the in-plane direction of the board, compared to the case of not having the lenses **16a**. Therefore, the function of dispersing light to oblique directions in the case of having the lenses **16a** is higher than that of the case of not having the lenses **16a**. That is, the view angle characteristics of a display device can be increased. Here, the term "increase of the view angle characteristics" means that the degree of a decrease in luminance when the organic EL display device was viewed

from a direction oblique to the board compared to that when it was viewed from the direction perpendicular to the board is reduced.

Furthermore, the degree of improvement in the view angle characteristics depends on the light-emitting area, the curvature of the lens **16a**, and the distance from the light-emitting face to the lens **16a**. The lens **16a** can be designed using these factors as parameters.

Next, the curvature of the lens **16a** and the view angle characteristics will be described. FIG. 3 shows changes in correlation between emission angle and relative luminance when lens curvature radius R (μm) of the lens **16a** is varied. The term "flat" in FIG. 3 means a case of not being provided with the lens **16a**.

The measurement was carried out for lenses **16a** having four different lens curvature radii R (20, 30, 60, and 100 μm). The measurement conditions were as follows: The pixel pitch was 31.5 μm , the maximum width of the lens **16a** was 31.5 μm , and the width of the light-emitting region (the light-emitting region of one pixel defined by pixel separation layers) was 16.5 μm . Furthermore, the cathode electrode was made of a mixture of indium oxide and zinc oxide and had a refractive index of 1.9 and a thickness of 0.05 μm . The first protective layer is made of SiN and had a refractive index of 1.83 and a thickness of 0.18 μm . The second protective layer was made of an epoxy resin and had a refractive index of 1.54 and a minimum thickness of 10 μm . The third protective layer was made of SiN and had a refractive index of 1.83 and a thickness of 1 μm . The distance from the light-emitting face to the lens **16a** at the position between adjacent pixels, where the second protective layer has the maximum thickness, were 17.7, 14.5, 12.1, and 11.2 μm for the lens curvature radii R 20, 30, 60, and 100 μm , respectively.

The term "relative luminance" means the luminance relatively determined in each structure on the assumption that the luminance when the emission angle is 0 degree is 1.

The emission angle is the angle of spread of light beams emitted from the third protective layer **17**. It is confirmed from FIG. 3 that the relative luminance is hard to reduce in those provided with the lenses **16a** compared to one not provided with the lenses **16a**. Furthermore, it is confirmed that among those provided with the lenses **16a**, the relative luminance is hard to reduce in those having smaller lens curvature radius R.

This is because since the lens **16a** is a diverging lens, the light beams incident on the lens **16a** diverge in-plane direction of the board, which gives a display being bright and having good view angle characteristics, even if the display device is obliquely viewed (the view angle becomes large).

Incidentally, the term "diverging lens" means a lens that enlarges the refracting angle of a light ray obliquely incident on the lens compared to a case of being flat (not having a lens) and has a function of further diverging light beams. Therefore, the refractive index in the region (for example, an air layer or a resin layer) outer than the third protective layer **17** (the upper side of the paper) can be smaller than those in the first protective layer **15**, the second protective layer **16**, and the third protective layer **17**.

Process of Manufacturing Display Device

Next, a process of manufacturing a display device according to the embodiment will be described with reference to FIGS. 4A to 4F. FIGS. 4A to 4F are schematic cross-sectional views illustrating each step of a process of manufacturing a display device of the embodiment. Incidentally, since the steps until the cathode electrode **14** is formed are well known

manufacturing steps, the descriptions thereof are omitted here. First, as shown in FIG. 4A, a board **10** provided with a plurality of top-emission-type organic EL elements is prepared. The organic EL elements are formed above the board **10** provided with active-matrix pixel circuits (not shown) through an interlayer insulating layer and a planarizing layer (not shown) and comprise anode electrodes **11**, pixel separation layers **12**, an organic EL layer **13**, and a cathode electrode **14**.

Then, as shown in FIG. 4B, a first protective layer **15** is formed in the entire area of the display region. The first protective layer **15** is a member having a sealing function of preventing moisture contained in the resin material constituting a second protective layer, which is formed on the first protective layer **15**, from coming into contact with the organic EL elements. Accordingly, the first protective layer **15** can be a member having a high light transmittance and being excellent in moisture-proof property and can be made of a silicon nitride layer or a silicon oxynitride layer.

Then, as shown in FIG. 4C, a second protective layer **16** is formed on the first protective layer **15** in the entire region of the display region. The second protective layer **16** is made of a resin material and has a thickness of about 10 μm or more and 100 μm or less so that the second protective layer **16** can sufficiently cover dust such as etching residues and also absorb the asperities of the pixel separation layers **12** made of an acrylic resin. The resin material can be a thermosetting resin, a thermoplastic resin, or a photo-setting resin, which are low in moisture content. When a thermosetting resin or a photo-setting resin is used, the second protective layer **16** can be formed by, for example, spin coating or a dispense method. Alternatively, a thermoplastic resin layer having a thickness of 10 μm or more and 100 μm or less may be laminated on the first protective layer **15** under vacuum. Specific examples of the resin material include epoxy resins and butyl resins.

Then, as shown in FIG. 4D, a mold **21** for forming lenses **16a** is prepared, and the lenses **16a** are formed by pressing the mold **21** to the resin material of the second protective layer **16** while avoiding air bubbles from being included in the resin material.

The mold **21** can be made of a usual metal, but when the resin material is a photo-setting resin, since the mold **21** is required to transmit light, a quartz substrate can be used. Furthermore, in order to enhance the removal of the mold **21** from the resin material, the mold **21** may be provided with a layer such as a fluorine resin layer on the surface.

When the resin material is a thermosetting resin, the mold **21** is placed so that the tops of the mold **21** for forming concave lenses approximately correspond to the centers of the respective pixels, and in such a state, the resin is cured by heating to 80° C.

The curing temperature can be about 80° C., because the heat-proof temperature of an organic compound making up the organic EL layer **13** may be about 100° C.

Then, as shown in FIG. 4E, the mold **21** is removed from the cured resin material.

By doing so, lenses **16a** corresponding to the respective pixels are formed on the surface of the second protective layer **16**.

Incidentally, if the bottom of each concave lens **16a** is excessively thin, dust such as etching residues cannot be sufficiently covered, which causes occurrence of pinholes. Therefore, the minimum thickness of the second protective layer **16** at the bottom of the concave can be 1 μm or more. Furthermore, the maximum thickness of the second protective layer **16** at the bottom of each concave lens **16a** can be 50

μm or less for preventing a decrease in light quantity due to absorption and a leakage of light emitted from an adjacent pixel.

Lastly, as shown in FIG. 4F, the above-described third protective layer **17** is formed on the cured second protective layer **16** in the entire area of the display region. The third protective layer **17** can be a member having a high light transmittance and being excellent in moisture-proof property and can be made of a silicon nitride layer or a silicon oxynitride layer. The first protective layer **15** and the third protective layer **17** may be made of the same material or different materials.

Here, in the display device, as shown in FIG. 5, the first protective layer **15** and the third protective layer **17** are in direct contact with each other at the periphery region, which is the outside of the display region provided with the organic EL elements and is not provided with the organic EL elements. Thus, the first protective layer **15** and the third protective layer **17** are formed so as to have the second protective layer **16** therebetween. That is, it is given a structure in which the second protective layer **16** is sealed with the first protective layer **15** and the third protective layer **17**.

Therefore, moisture in outside air does not penetrate into the resin material constituting the second protective layer **16**.

In addition, as shown in FIG. 5, the first protective layer **15** and the interlayer insulating layer **51**, which is formed between the board **10** and the planarizing layer **52**, are in direct contact with each other in the peripheral region and are formed so as to have the planarizing layer **52**, the organic EL layer **13**, the cathode electrode **14**, and the pixel separation layers (not shown) therebetween. That is, it is given a structure in which the planarizing layer **52**, the organic EL layer **13**, the cathode electrode **14**, and the pixel separation layers are sealed with interlayer insulating layer **51** and the first protective layer **15**. Since the interlayer insulating layer **51** is made of an inorganic material such as silicon nitride or silicon oxynitride and is excellent in moisture-proof property, it can prevent moisture from penetrating into the inside of the display region from the outside through the planarizing layer **52** and the pixel separation layers.

Incidentally, in the steps of forming the lenses **16a** shown in FIGS. 4C, 4D, and 4E, a method of direct forming using the mold **21** has been described, but the lenses **16a** can also be produced by another method such as any of the following i) to v):

- i) a method involving heating a resin layer patterned by, for example, photolithography and deforming the resin layer into a lens shape by reflow;
- ii) a method of forming lenses by exposing a photo-setting resin layer having a uniform thickness with light having a distribution in the in-plane direction and developing the resin layer;
- iii) a method of processing a surface of a resin material formed so as to have a uniform thickness using ion beams, electron beams, or a laser into a lens shape;
- iv) a method of self-alignedly forming lens by dropping a resin in an appropriate amount to each pixel; and
- v) a method of forming lenses by separately preparing a board provided with organic EL elements and a resin sheet provided with lenses in advance and aligning and bonding them to each other.

The concave lens **16a** according to aspects of the present invention may have a hemispherical or a U-shaped semi-cylindrical front face. When the lens is U-shaped semi-cylindrical, the view angle characteristics are particularly improved in either the vertical or horizontal direction. Fur-

thermore, the ends in the length direction of the semi-cylindrical lens may be hemispherical or may be vertical to the board.

Incidentally, the display device according to aspects of the present invention can be applied to, for example, televisions, car navigation systems, and digital camera back monitors, where improvement in view angle characteristics is important.

Aspects of the present invention are not limited to the above-described configurations, and various application and modification are possible as long as it does not deviate from the above-described spirit.

EXAMPLES

Example 1

Pixel circuits (not shown) were formed on a glass substrate with low-temperature polysilicon TFTs, and an interlayer insulating layer of SiN and a planarizing layer of an acrylic resin were formed in this order on the pixel circuits to produce a board **10** shown in FIG. 4A. Then, an ITO layer and an AlNd layer were formed on the board **10** so as to respectively have thicknesses 38 nm and 100 nm by sputtering. Subsequently, the ITO layer and the AlNd layer were patterned for each pixel to form anode electrodes **11**.

Then, an acrylic resin was spin coated on the anode electrodes **11** and then was patterned by lithography to form openings (these openings correspond to pixels) at the portions where the anode electrodes **11** were provided to form pixel separation layers **12**. The pitch of the pixels was 30 μm , and the size of the exposed portion of each anode electrode **11** due to the opening was 10 μm . Then, ultrasonic cleaning with isopropyl alcohol (IPA), boiling cleaning, and drying were conducted. Furthermore, after UV and ozone cleaning, an organic EL layer **13** was formed by vacuum deposition.

In the formation of the organic EL layer **13**, first, a hole-transporting layer with a thickness of 87 nm was formed over the entire pixels. In this step, the degree of vacuum was 1×10^{-4} Pa, and the deposition rate was 0.2 nm/sec.

Then, a red light-emitting layer, a green light-emitting layer, and a blue light-emitting layer were formed at thicknesses of 30 nm, 40 nm, and 25 nm, respectively, using a shadow mask.

Subsequently, an electron-transporting layer common for all pixels was formed by vacuum deposition of bathophenanthroline (Bphen) at a thickness of 10 nm. In the vacuum deposition, the degree of vacuum was 1×10^{-4} Pa, and the deposition rate was 0.2 nm/sec.

Then, a common electron-injection layer was formed by co-vapor deposition of Bphen and Cs_2CO_3 (weight ratio of 90:10) at a thickness of 40 nm. In the vapor deposition, the degree of vacuum was 3×10^{-4} Pa, and the deposition rate was 0.2 nm/sec.

Then, the board provided with the organic EL layer **13** including from the hole-transporting layer to the electron-injection layer was transferred to a sputtering apparatus while keeping the vacuum. Then, as a cathode electrode **14**, an extremely thin Ag layer and a transparent electrode layer were formed at thicknesses of 10 nm and 50 nm, respectively, in this order. The transparent electrode layer was made of a mixture of indium oxide and zinc oxide.

Then, as shown in FIG. 4B, a first protective layer **15** of silicon nitride was formed by plasma CVD using SiH_4 gas, N_2 gas, and H_2 gas. Then, as shown in FIG. 4C, a second protective layer **16** of a thermosetting resin material (epoxy resin) with a viscosity of 3000 mPa·s was applied with a dispenser

(SHOT MINI SL: a product of Musashi Engineering, Inc.), which enables precise drawing, under a nitrogen atmosphere at a dew-point temperature of 60° C.

Before the thermosetting of the resin material, as shown in FIG. 4D, a separately prepared mold **21** for forming lenses **16a** was pressed to the surface of the resin material. In the pressing, the positioning was performed by adjusting an alignment mark of the mold **21** to an alignment mark of the board. As a result, the lenses **16a** were formed at positions corresponding to the respective pixels. The mold **21** had convex protrusions at the same pitch as the pixel pitch, and the surfaces of the protrusions were coated with a Teflon (registered trademark)-based resin as a release agent. The shape of the protrusion, that is, the shape of the lens **16a**, was formed so as to have a curvature radius of 30 μm . The resulting lens array had a pitch of 30 μm and a depth of about 4 μm .

Here, considering the environments of a clean room and a process apparatus, since the purpose of the second protective layer **16** is planarization by a resin material for the case of that foreign substances were present, the minimum thickness (film thickness at the thinnest portion) was determined to be 10 μm . Incidentally, the minimum thickness here was 10 μm , but may be 1 μm or more and 50 μm or less.

The resin material (epoxy resin) was cured by heating at 100° C. for 15 minutes under a vacuum environment in the state that the mold **21** was pressed as described above. Then, the mold **21** was removed from the resin to form the lenses **16a** as shown in FIG. 4E.

Furthermore, as shown in FIG. 4F, an inorganic protective layer (third protective layer **17**) of silicon nitride was formed by plasma CVD using SiH_4 gas, N_2 gas, and H_2 gas. The third protective layer **17** was formed so as to have a thickness of 1 μm and to cover the entire display region provided with the organic EL elements.

The thus produced display device according to aspects of the present invention was measured for the view angle characteristics and compared to those of a display device not provided with the lenses to confirm that the relative luminance at an emission angle of 60° was increased to approximately 0.4 from approximately 0.25 in the flat case.

In addition, since the second protective layer **16** provided with the lenses is completely sealed with the first protective layer **15** and the third protective layer **17**, moisture transmission to the resin does not occur even under a high-temperature and high-humidity environment. Therefore, the resin did not swell and no change occurred in the characteristics of the lenses.

Example 2

A lens array was formed by a process, which is different from that of EXAMPLE 1, as shown in FIGS. 6A to 6E. Incidentally, since the steps until the first protective layer **15** is formed are the same as those in EXAMPLE 1, the descriptions thereof are omitted, and the description will be started from the step of forming the second protective layer **16**.

First, a thermosetting epoxy resin (second protective layer **16** of a thermosetting resin material) with a viscosity of 3000 mPa·s was applied on the first protective layer **15** at a thickness of 10 μm with a dispenser (SHOT MINI SL: a product of Musashi Engineering, Inc.), which enables precise drawing, under a nitrogen atmosphere at a dew-point temperature of 60° C. (FIG. 6A). Then, the epoxy resin was cured by heating at 100° C. for 15 minutes under a vacuum environment.

Subsequently, the same resin **23** was applied on the second protective layer **16** at a thickness of 4 μm (FIG. 6B) and was exposed from above with a photomask **24** (FIG. 6C). The

exposure quantity was determined to have a two-dimensional distribution converted from the shape of lenses 16a. The exposed resin was developed to form the lenses 16a having a predetermined shape (FIG. 6D). In-plane control of the exposure quantity was performed by in-plane control of the transmittance of the photomask 24. Then, the resin was cured by heating again at 100° C. for 15 minutes under a vacuum environment. This heat treatment also has a function of smoothening the surfaces of the lenses. In addition, since the purpose is to embed foreign substances, when they are present, in the resin material, the minimum thickness (film thickness at the thinnest portion) of the second protective layer 16 was determined to be 10 μm. The minimum thickness may be 1 μm or more and 50 μm or less.

Finally, an inorganic protective layer (third protective layer 17) of silicon nitride was formed by plasma CVD using SiH₄ gas, N₂ gas, and H₂ gas. The third protective layer 17 was formed so as to have a thickness of 1 μm and to cover the entire area of the display region provided with the organic EL elements (FIG. 6E).

Incidentally, in the above-described EXAMPLES, the arrangement of the pixels is not referred, but the shape of the lenses 16a can be formed as follows, according to the arrangement of the pixels. FIG. 7 is a front view of a display device according to aspects of the present invention. As shown in FIG. 7, when the arrangement of pixels is an RGB delta arrangement, the lens 16a can be formed such that the outer shape when it is viewed from the front side of the display device is a circle. In FIG. 7, reference number 101 denotes an R (red light-emitting) pixel, reference number 102 denotes a G (green light-emitting) pixel, and reference number 103 denotes a B (blue light-emitting) pixel. Furthermore, reference number 104 shows the outer shape of the lens 16a. In FIG. 7, the RGB pixels are each provided with one lens 16a.

As shown in FIGS. 8A and 8B, when the pixels are arranged in a stripe arrangement, an elongated semicylindrical concave lens 16a can be formed so as to cover one pixel (organic EL element). Here, the same structure as that in FIG. 7 is shown with the same reference number. FIG. 8A is a front view of a display device according to aspects of the present invention. As shown in FIG. 8A, the RGB pixels are each provided with one lens 16a. FIG. 8B is a perspective view of the display device shown in FIG. 8A. In FIG. 8B, the first protective layer and the third protective layer are not shown. In the case of the lens array shown in FIGS. 8A and 8B, the view angle characteristics in the vertical direction of FIG. 8A were not improved, and the view angle characteristics toward the front were improved only in the horizontal direction of FIG. 8A.

FIGS. 9A and 9B show a modification of the elongated semicylindrical lenses 16a shown in FIGS. 8A and 8B. In this example, elongated semicylindrical lenses 16a are successively formed over the display region 107 in such a manner that one lens 16a corresponds to a plurality of pixels (organic EL elements) arranged in each column direction (the vertical direction of the paper). Here, the same structure as that in FIG. 7 is shown with the same reference number.

As shown in FIGS. 9A and 9B, lenses 16a each had a shape narrow and long in the vertical direction of the paper and were formed such that one lens 16a was common to pixels aligned in a line in the vertical direction of FIG. 9A. Specifically, one elongated semicylindrical lens 16a was formed for each alignment of R pixels, G pixels, and B pixels. The effect of improving the view angle characteristics is the same as that in the lenses shown in FIGS. 8A and 8B. That is, the view angle characteristics in the vertical direction of FIG. 9A were not

improved, and the view angle characteristics toward the front were improved only in the horizontal direction of FIG. 9A.

Furthermore, in addition to the above-mentioned examples, elongated semicylindrical lenses 16a may be formed such that a plurality of the lenses 16a correspond to a plurality of pixel groups aligned in a line from one end to the other end of the display region 107 in the vertical direction of the paper (not shown).

In addition, in the delta arrangement of RGB pixels shown in FIG. 7, the lenses may have a shape narrow and long in the horizontal direction of FIG. 7. In such a case, the view angle characteristics are not improved in the horizontal direction of FIG. 7, and the view angle characteristics toward the front can be improved only in the vertical direction of FIG. 7.

Aspects of the present invention may thus provide a display device having organic EL elements with a reduced occurrence of dark spots, and that achieve satisfactory view angle characteristics and also can be produced at low cost.

According to aspects of the present invention, particles such as etching residues and dust can be sufficiently covered with the second protective layer made of a resin material, which readily allows an increase in the thickness, and the view angle characteristics of light are improved by the function of the lenses. Furthermore, since the third protective layer made of an inorganic material is disposed on the surfaces of the lenses, the lenses are prevented from being changed with the passage of time, which stably increases the view angle characteristics of light. Furthermore, since the second protective layer made of a resin material is provided with the lenses without forming additional resin layer for the lenses, the total number of layers can be reduced, which leads a reduction in manufacturing cost.

While the present invention has been described with reference to exemplary embodiments, it is to be understood that the invention is not limited to the disclosed exemplary embodiments. The scope of the following claims is to be accorded the broadest interpretation so as to encompass all such modifications and equivalent structures and functions.

This application claims the benefit of Japanese Patent Application No. 2009-230648 filed Oct. 2, 2009, which is hereby incorporated by reference herein in its entirety.

What is claimed is:

1. A display apparatus comprising: a plurality of organic EL elements and a protective layer disposed on the plurality of the organic EL elements, wherein the protective layer comprises a first protective layer made of an inorganic material, a second protective layer made of a resin material and disposed on the first protective layer, and a third protective layer made of an inorganic material and disposed on the second protective layer; the second protective layer includes lenses for diverging at least part of light emitted from the organic EL element; the display apparatus including a display region provided with the organic EL elements and a periphery region disposed around the display region; and the first protective layer and the third protective layer are in contact with each other in the periphery region.
2. The display apparatus according to claim 1, wherein the lenses are arranged in such a manner that one lens corresponds to one organic EL element.
3. The display apparatus according to claim 1, wherein the shape of lens is an elongated concave.
4. The display apparatus according to claim 1, the lens is common to a plurality of organic EL elements.

- 5. The display apparatus according to claim 1, further comprising a planarizing layer; the organic EL element disposed on the planarizing layer; wherein the first protective layer is in contact with the planarizing layer in the periphery region. 5
- 6. The display apparatus according to claim 5, further comprising an interlayer insulating layer made of an inorganic material; the planarizing layer disposed on the interlayer insulating layer, wherein the first protective layer is in contact with the interlayer insulating layer in the periphery region. 10
- 7. The display apparatus according to claim 1, wherein the second protective layer has a thickness of 1 μm or more and 50 μm or less. 15
- 8. A digital camera comprising the display apparatus according to claim 1.
- 9. A car navigation system comprising the display apparatus according to claim 1. 20

* * * * *

专利名称(译)	显示设备		
公开(公告)号	US9024302	公开(公告)日	2015-05-05
申请号	US13/917356	申请日	2013-06-13
[标]申请(专利权)人(译)	佳能株式会社		
申请(专利权)人(译)	佳能株式会社		
当前申请(专利权)人(译)	佳能株式会社		
[标]发明人	SUMIDA NOA SAKAGUCHI KIYOFUMI		
发明人	SUMIDA, NOA SAKAGUCHI, KIYOFUMI		
IPC分类号	H01L27/32 H01L51/52		
CPC分类号	H01L51/5253 H01L51/5246 H01L51/5256 H01L51/5275 H01L27/32 H01L27/3244 H01L51/5237		
优先权	2009230648 2009-10-02 JP		
其他公开文献	US20130277659A1		
外部链接	Espacenet USPTO		

摘要(译)

一种显示装置，包括像素阵列，所述像素阵列包括多个有机EL元件，每个有机EL元件具有一对电极，有机化合物层包括发光层，并设置在所述一对电极之间，并且包括设置在所述多个电极上的保护层。有机EL元素。保护层具有由无机材料制成的第一保护层，由树脂材料制成并设置在第一保护层上的第二保护层，以及由无机材料制成并设置在第二保护层上的第三保护层。第二保护层包括用于使从发光层发射的光的至少一部分发散的透镜。镜片具有细长的凹形。

